

UMAREX

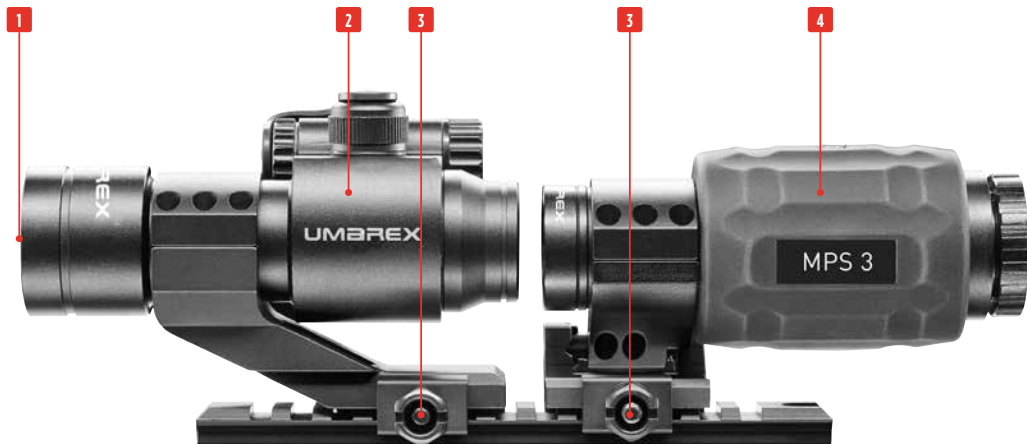

MPS 3



EN 01 Lens
02 Red dot sight
03 Mounting
04 Magnifier

DE 01 Objektiv
02 Rotpunktvisier
03 Montage
04 Vergrößerungsglas

FR 01 Objectif
02 Viseur point rouge
03 Montage
04 Verre grossissant

ES 01 Lente
02 Mira de punto rojo
03 Montaje
04 Lente de aumento

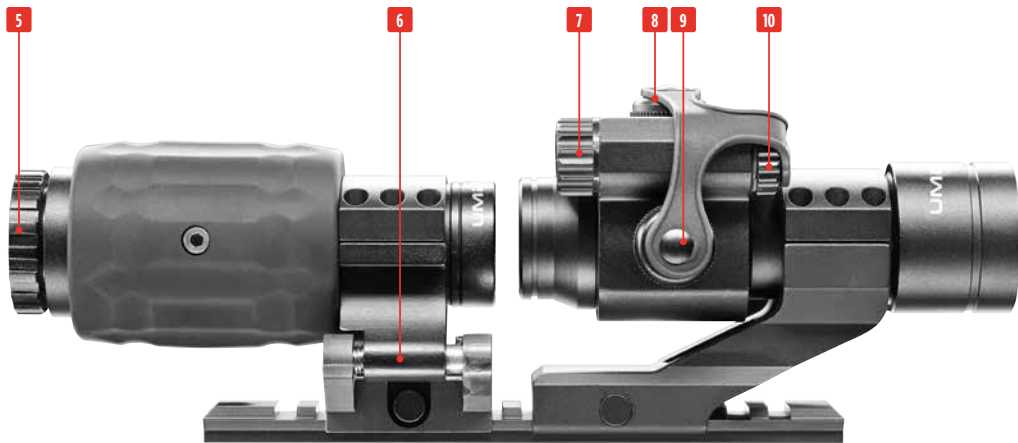

EN 05 Ocular with focus
06 Flip mount
07 Brightness adjustment
08 Elevation adjustment
09 Windage adjustment
10 Battery compartment

DE 05 Okular mit Scharfstellung
06 Schwenkmontage
07 Helligkeitsregler
08 Höhenverstellung
09 Seitenverstellung
10 Batteriefach

FR 05 Oculaire avec focalisation
06 Dispositif de montage pivotant
07 Réglage d'intensité de luminosité
08 Réglage en hauteur
09 Réglage en dérive
10 Compartiment de batterie

ES 05 Ocular con enfoque
06 Montaje pivotante
07 Regulador de luminosidad
08 Ajuste de la altura
09 Ajuste en deriva
10 Cámara para pilas

2

MOUNTING • MONTAGE • MONTAGE • MONTAJE

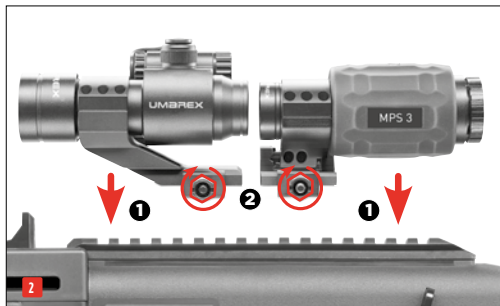
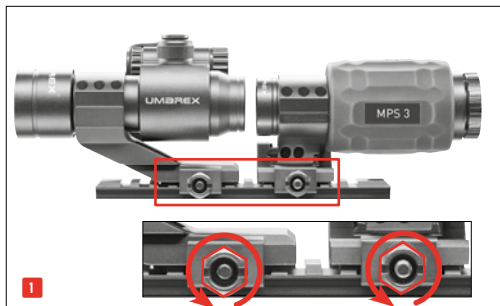
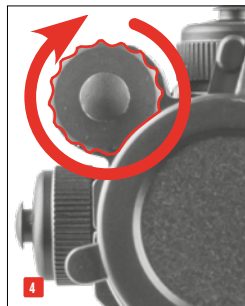
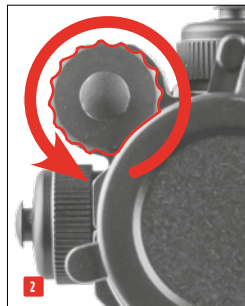
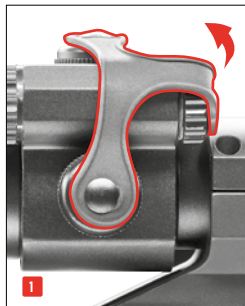
**3**BATTERY CHANGE • BATTERIEWECHSEL
CHANGEMENT DE LA BATTERIE • CAMBIO DE LA BATERÍA

4

BRIGHTNESS ADJUSTMENT • HELLIGKEITSREGLER
 RÉGLAGE D'INTENSITÉ DE LUMINOSITÉ • REGULADOR DE LUMINOSIDAD

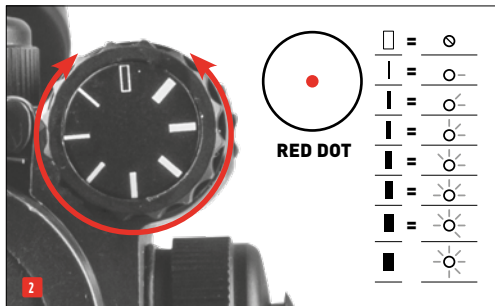
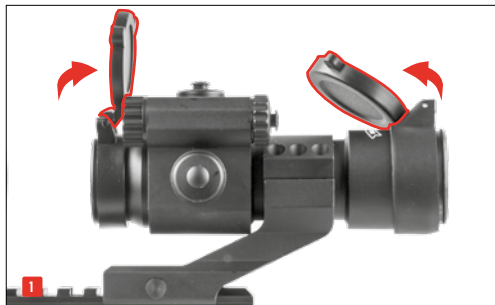
**5**

FOCUSING • SCHARFEINSTELLUNG
 MISE AU POINT • ENFOQUE

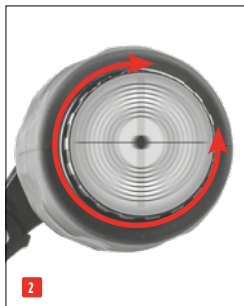
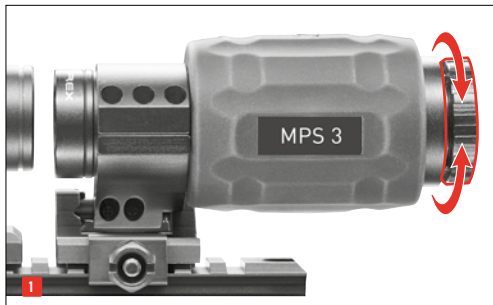

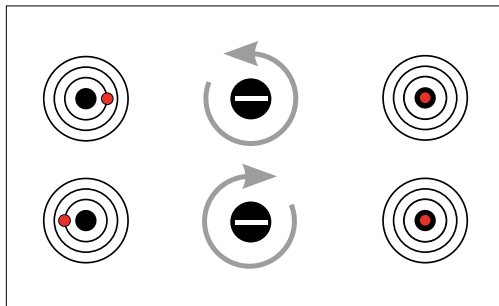
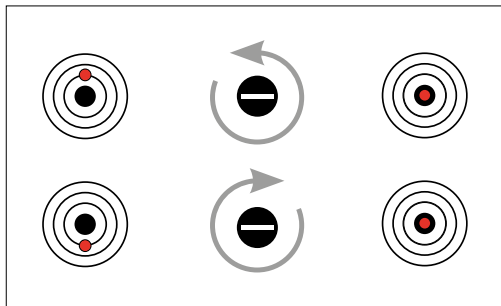
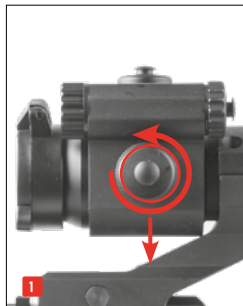
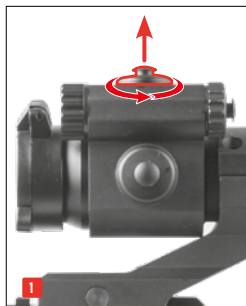

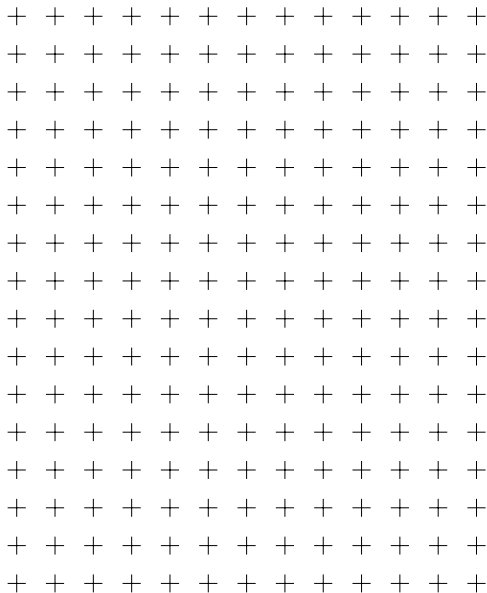
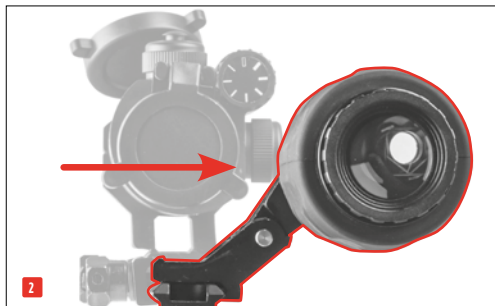
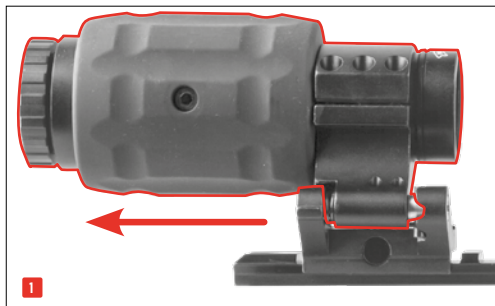

Battery Type • Batterietyp • Type de Piles • Tipo de Batería	LR44
Possible batteries • Anzahl benötigter Batterien • Batteries possibles • Posibles baterías	2
Mount • Montage • Montage • Montaje	Picatinny
Magnificaton • Vergrößerung • Grossissement • Ampliación:	3x
Objective • Objectiv • Objectif • Objetivo	30 mm
Ocular • Okular • Okular • Ocular	26 mm
Field of view • Sichtfeld • Champ visuel • Campo visual	110 cm/10 m
Reticule adjustment • Absehenverstellung • Réglage du réticule • Ajuste de la retícula	1 click: 0,12 cm/10 m, max. 50 clicks/rotation 1 Klick: 0,12 cm/10 m, max. 50 Klicks/Umdrehung 1 clic: 0,12 cm/10 m, max. 50 clics/rotation 1 clic: 0,12 cm/10 m, máx. 50 clics/vuelta
Brightness settings • Helligkeitsstufen • Degrés de luminosité • Niveles de luminosidad	7
Weight of red dot sight including mount • Gewicht Rotpunktvisier inkl. Montage • Poids du viseur point rouge, dispositif de montage compris • Peso de la mira de punto rojo incl. montaje	342 g
Length of red dot sight • Rotpunktvisierlänge • Longueur du viseur point rouge • Longitud de la mira de punto rojo	138 mm
Weight of magnifier including flip mount • Gewicht Vergrößerungsglas inkl. Schwenkmontage • Poids du verre grossissant, dispositif de montage pivotant compris • Peso de la lente de aumento incl. montaje pivotante	421 g
MOA	4

UMAREX

EN We reserve the right to make color and design changes and technical improvements. No responsibility is accepted for printing errors or incorrect information. **DE** Änderungen in Farbe und Design sowie technische Verbesserungen, Druckfehler und Irrtum vorbehalten. Alle Angaben ohne Gewähr. **FR** Sauf modifications de la couleur et du design ainsi que des améliorations techniques, erreurs d'impression et erreur. Toutes les données sont fournies sans garantie. **ES** Salvo modificaciones de color y de diseño así como mejoramientos técnicos, erratas y error. Todos los datos sin garantía.



UMAREX GmbH & Co. KG • Donnerfeld 2 • 59757 Arnsberg • Germany • service@umarex.de

WWW.UMAREX.COM

Covers models:
2.1033